



US007727266B2

(12) **United States Patent**  
**Lindemann et al.**

(10) **Patent No.:** **US 7,727,266 B2**  
(45) **Date of Patent:** **Jun. 1, 2010**

(54) **METHOD AND APPARATUS FOR RETAINING SCREWS IN A PLATE**

(75) Inventors: **Gary S. Lindemann**, Collierville, TN (US); **Larry Gause**, Memphis, TN (US); **Robert A. Farris**, Cordova, TN (US); **Regis W. Haid, Jr.**, Atlanta, GA (US); **Stephen Papadopoulos**, Paradise Valley, AZ (US); **Rick Sasso**, Carmel, IN (US); **Volker Sonntag**, Phoenix, AZ (US); **Vince Traynelis**, Iowa City, IA (US); **Iain Kalfas**, Beachwood, OH (US)

5,290,312 A	3/1994	Kojimoto et al.
5,318,567 A	6/1994	Vichard
5,364,399 A	11/1994	Lowery et al.
5,470,333 A	11/1995	Ray
5,484,439 A	1/1996	Olson et al.
5,484,440 A	1/1996	Allard
5,520,690 A	5/1996	Errico et al.
5,531,746 A	7/1996	Errico et al.
5,549,607 A	8/1996	Olson et al.
5,549,612 A	8/1996	Yapp et al.
5,562,661 A	10/1996	Yoshimi et al.
5,578,034 A	11/1996	Estes

(Continued)

(73) Assignee: **Warsaw Orthopedic, Inc.**

**FOREIGN PATENT DOCUMENTS**

(\* ) Notice: Subject to any disclaimer, the term of this patent is extended or adjusted under 35 U.S.C. 154(b) by 1643 days.

EP 1 346 697 A2 9/2003

(Continued)

*Primary Examiner*—Eduardo C Robert  
*Assistant Examiner*—David Comstock

(21) Appl. No.: **10/870,026**

(22) Filed: **Jun. 17, 2004**

(57) **ABSTRACT**

(65) **Prior Publication Data**

US 2005/0283152 A1 Dec. 22, 2005

A retention system for maintaining a screw to a vertebral plate. One or more screws extend through apertures within the vertebral plate. A cavity is positioned adjacent to and overlaps into the aperture. A ring is positioned within the cavity and held in position by a cap. The cap attaches to the plate to prevent removal of the ring. The ring is deflectable between a first shape to allow the screw to be inserted and removed from the aperture, and a second shape to prevent screw back-out from the aperture. A method of using the system is also included and comprises positioning the ring within a cavity in the plate, maintaining the position of the ring to the plate by attaching a cap, inserting a screw through the aperture and attaching the plate to a vertebral member, and positioning the ring over the screw head and preventing the screw from backing-out.

(51) **Int. Cl.**  
**A61B 17/80** (2006.01)

(52) **U.S. Cl.** ..... **606/289**

(58) **Field of Classification Search** ..... 606/61,  
606/69-71; 403/7, 9, 330, 350, 374.1, 379.2,  
403/409.1

See application file for complete search history.

(56) **References Cited**

**U.S. PATENT DOCUMENTS**

5,085,548 A	2/1992	Moyles
5,098,435 A	3/1992	Stednitz et al.
5,261,910 A	11/1993	Warden et al.

**25 Claims, 5 Drawing Sheets**

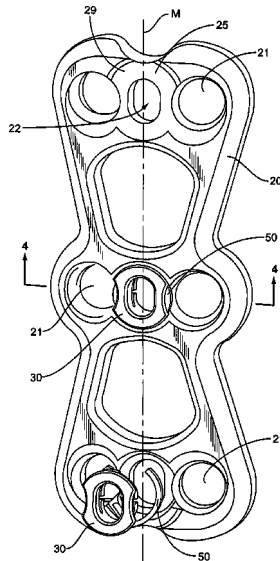

U.S. PATENT DOCUMENTS			FOREIGN PATENT DOCUMENTS				
5,607,426	A	3/1997	Ralph et al.	6,660,004	B2	12/2003	Barker et al.
5,611,800	A	3/1997	Davis et al.	6,666,867	B2	12/2003	Ralph et al.
5,616,144	A	4/1997	Yapp et al.	6,669,700	B1	12/2003	Farris et al.
5,634,925	A	6/1997	Urbanski	6,679,883	B2	1/2004	Hawkes et al.
5,676,666	A	10/1997	Oxland et al.	6,682,564	B1	1/2004	Duarte
5,681,311	A	10/1997	Foley et al.	6,689,134	B2	2/2004	Ralph et al.
5,713,900	A	2/1998	Benzel et al.	6,695,845	B2	2/2004	Dixon et al.
5,728,098	A	3/1998	Sherman et al.	6,695,846	B2	2/2004	Richelsoph et al.
5,735,853	A	4/1998	Olerud	6,702,817	B2	3/2004	Beger et al.
5,735,899	A	4/1998	Schwartz et al.	6,755,833	B1	6/2004	Paul et al.
5,766,254	A	6/1998	Gelbard	6,761,719	B2	7/2004	Justis et al.
5,800,433	A	9/1998	Benzel et al.	6,780,186	B2	8/2004	Errico et al.
5,843,082	A	12/1998	Yuan et al.	6,793,658	B2	9/2004	LeHuec et al.
5,876,402	A	3/1999	Errico et al.	2002/0013586	A1	1/2002	Justis et al.
5,904,683	A	5/1999	Pohndorf et al.	2002/0045897	A1	4/2002	Dixon et al.
5,931,838	A	8/1999	Vito	2002/0045898	A1	4/2002	Freid et al.
5,954,722	A	9/1999	Bono	2002/0058939	A1	5/2002	Wagner et al.
5,954,725	A	9/1999	Sherman et al.	2002/0065517	A1	5/2002	Paul
6,004,321	A	12/1999	Graser	2002/0082603	A1	6/2002	Dixon et al.
6,017,345	A	1/2000	Richelsoph	2002/0111630	A1	8/2002	Ralph et al.
6,030,389	A	2/2000	Wagner et al.	2002/0120273	A1	8/2002	Needham et al.
6,036,693	A	3/2000	Yuan et al.	2002/0128655	A1	9/2002	Michelson
6,077,267	A	6/2000	Huene	2002/0147450	A1	10/2002	LeHuec et al.
6,117,135	A	9/2000	Schlapfer	2002/0183754	A1	12/2002	Michelson
6,117,713	A	9/2000	Hoshino et al.	2002/0183755	A1	12/2002	Michelson
6,132,434	A	10/2000	Sherman et al.	2003/0018335	A1	1/2003	Michelson
6,152,927	A	11/2000	Farris et al.	2003/0023242	A1	1/2003	Harrington, Jr.
6,159,213	A	12/2000	Rogozinski	2003/0036759	A1	2/2003	Musso
6,189,422	B1	2/2001	Stihl	2003/0040749	A1	2/2003	Grabowski et al.
6,193,720	B1	2/2001	Yuan et al.	2003/0045880	A1	3/2003	Michelson
6,224,602	B1	5/2001	Hayes	2003/0060828	A1	3/2003	Michelson
6,228,085	B1	5/2001	Theken et al.	2003/0093082	A1	5/2003	Campbell et al.
6,235,034	B1	5/2001	Bray	2003/0105462	A1	6/2003	Haider
6,241,731	B1	6/2001	Fiz	2003/0149434	A1	8/2003	Paul
6,258,089	B1	7/2001	Campbell et al.	2003/0181912	A1	9/2003	Michelson
6,261,291	B1	7/2001	Talaber et al.	2003/0187440	A1	10/2003	Richelsoph et al.
6,273,888	B1	8/2001	Justis	2003/0191471	A1	10/2003	Michelson
6,273,889	B1	8/2001	Richelsoph	2003/0191472	A1	10/2003	Michelson
6,287,311	B1	9/2001	Sherman et al.	2003/0208204	A1	11/2003	Bailey et al.
6,302,883	B1	10/2001	Bono	2003/0225409	A1	12/2003	Freid et al.
6,306,136	B1	10/2001	Baccelli	2003/0236528	A1	12/2003	Thramann
6,331,179	B1	12/2001	Freid et al.	2004/0019353	A1	1/2004	Freid et al.
6,342,055	B1	1/2002	Eisermann et al.	2004/0030336	A1	2/2004	Khanna
6,361,537	B1	3/2002	Anderson	2004/0030338	A1	2/2004	Paul
6,383,186	B1	5/2002	Michelson	2004/0034352	A1	2/2004	Needham et al.
6,398,783	B1	6/2002	Michelson	2004/0034354	A1	2/2004	Paul
6,402,756	B1	6/2002	Ralph et al.	2004/0039387	A1	2/2004	Gause et al.
6,413,259	B1	7/2002	Lyons et al.	2004/0068319	A1	4/2004	Cordaro
6,416,528	B1	7/2002	Michelson	2004/0087951	A1	5/2004	Khalili
6,428,542	B1	8/2002	Michelson	2004/0097934	A1	5/2004	Farris et al.
6,440,136	B1	8/2002	Gambale et al.	2004/0097935	A1	5/2004	Richelsoph et al.
6,454,769	B2	9/2002	Wagner et al.	2004/0097938	A1	5/2004	Alleyne
6,454,771	B1	9/2002	Michelson	2004/0097940	A1	5/2004	Paul
6,454,773	B1	9/2002	Sherman et al.	2004/0106924	A1	6/2004	Ralph et al.
6,485,491	B1	11/2002	Farris et al.	2004/0127897	A1	7/2004	Freid et al.
6,503,250	B2	1/2003	Paul	2004/0127899	A1	7/2004	Konieczynski et al.
6,513,814	B2	2/2003	White	2004/0127900	A1	7/2004	Konieczynski et al.
6,527,776	B1	3/2003	Michelson	2004/0127904	A1	7/2004	Konieczynski et al.
6,533,786	B1	3/2003	Needham et al.	2004/0133205	A1	7/2004	Thramann et al.
6,592,586	B1	7/2003	Michelson	2004/0153069	A1	8/2004	Paul
6,599,290	B2	7/2003	Bailey et al.	2004/0158246	A1	8/2004	Assaker et al.
6,602,255	B1	8/2003	Campbell et al.	2004/0181227	A1	9/2004	Khalili
6,602,256	B1	8/2003	Hayes	2004/0210219	A1	10/2004	Bray
6,602,257	B1	8/2003	Thramann	2004/0220566	A1	11/2004	Bray
6,605,090	B1	8/2003	Trieu et al.	2004/0220571	A1	11/2004	Assaker et al.
6,620,163	B1	9/2003	Michelson	2004/0236333	A1	11/2004	Lin
6,626,907	B2	9/2003	Campbell et al.				
6,652,525	B1	11/2003	Assaker et al.	EP	1346697	A2	9/2003
6,656,181	B2	12/2003	Dixon et al.	FR	2 794 963	A1	12/2000
				WO	WO 95/35067		12/1995

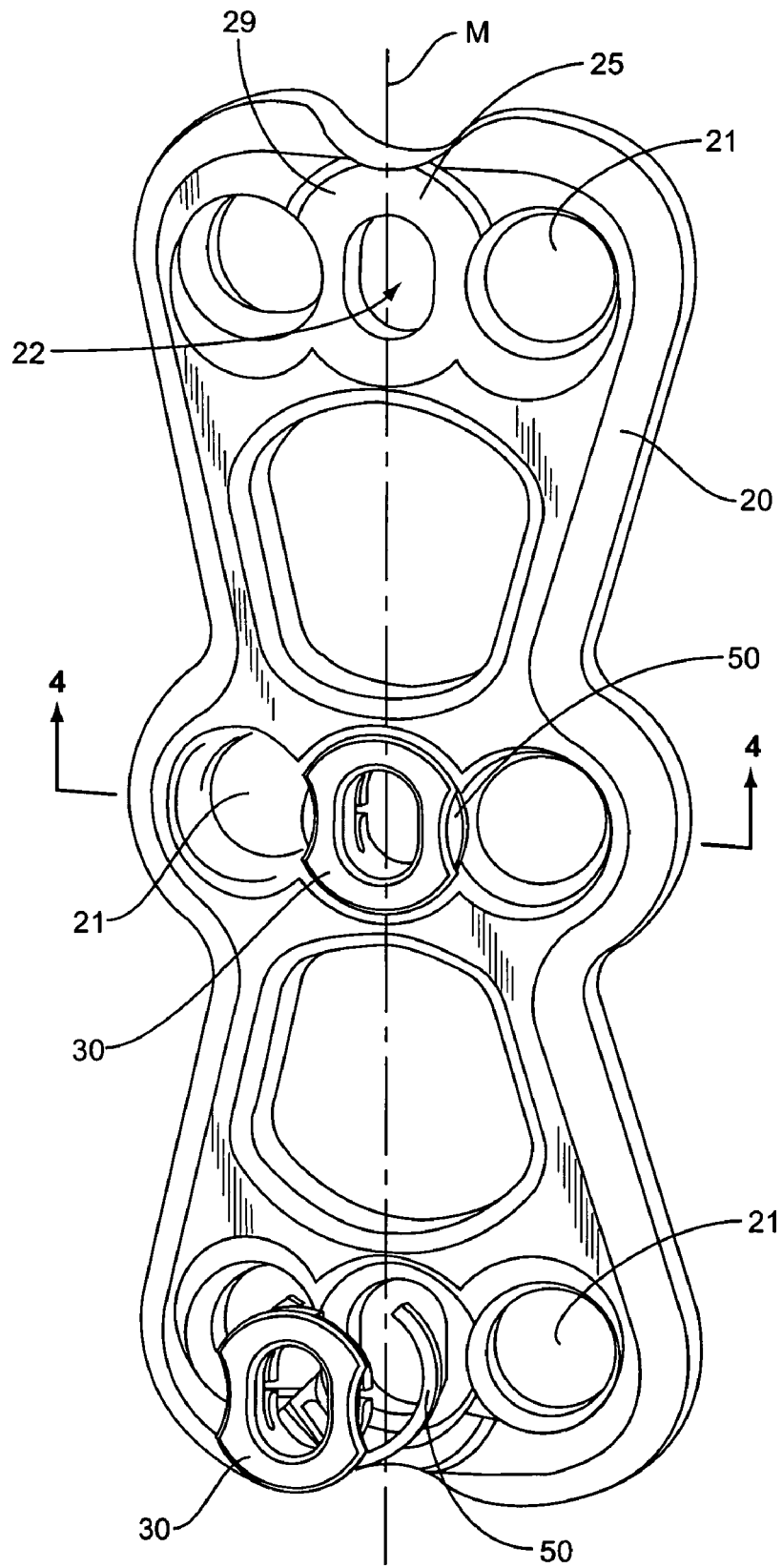

FIG. 1

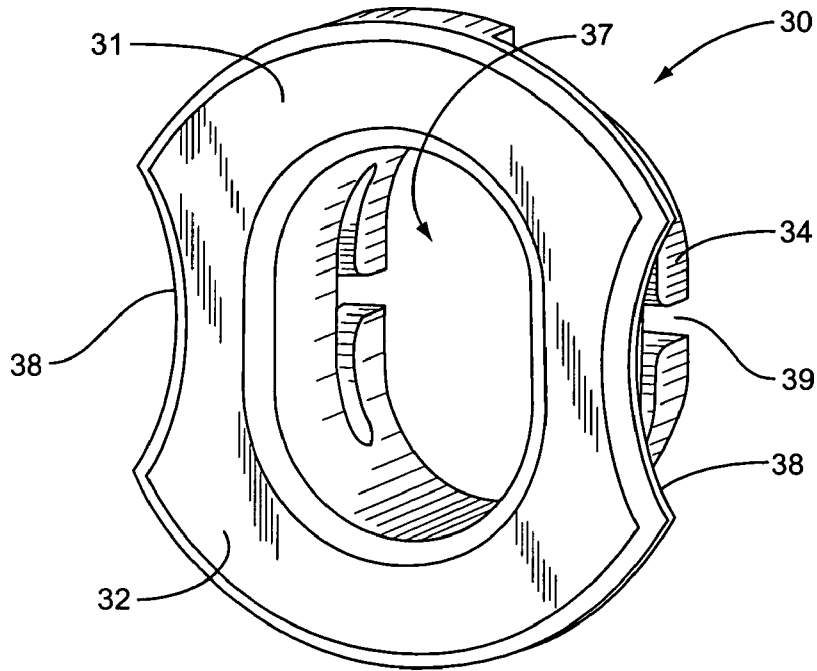

FIG. 2

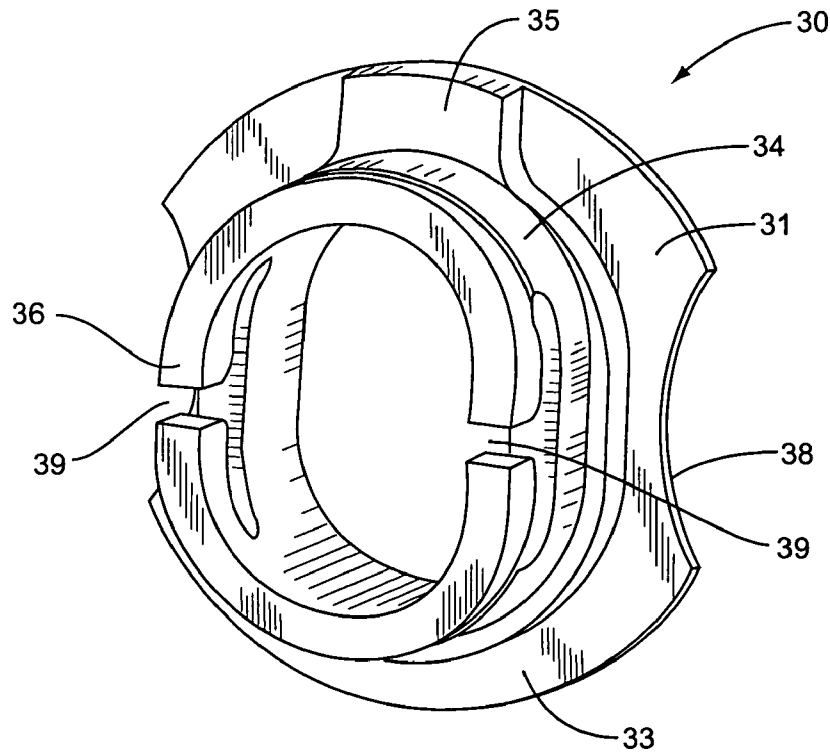

FIG. 3

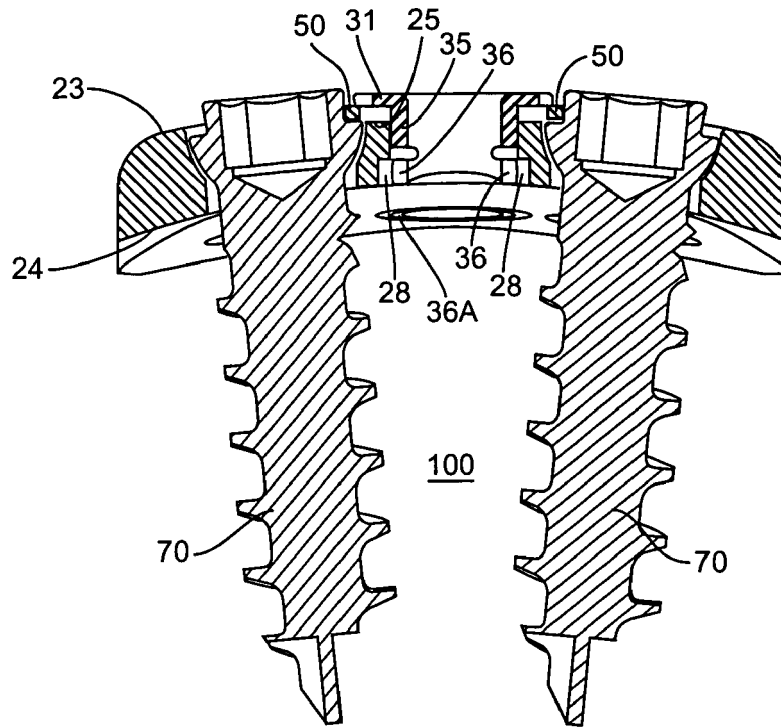

FIG. 4

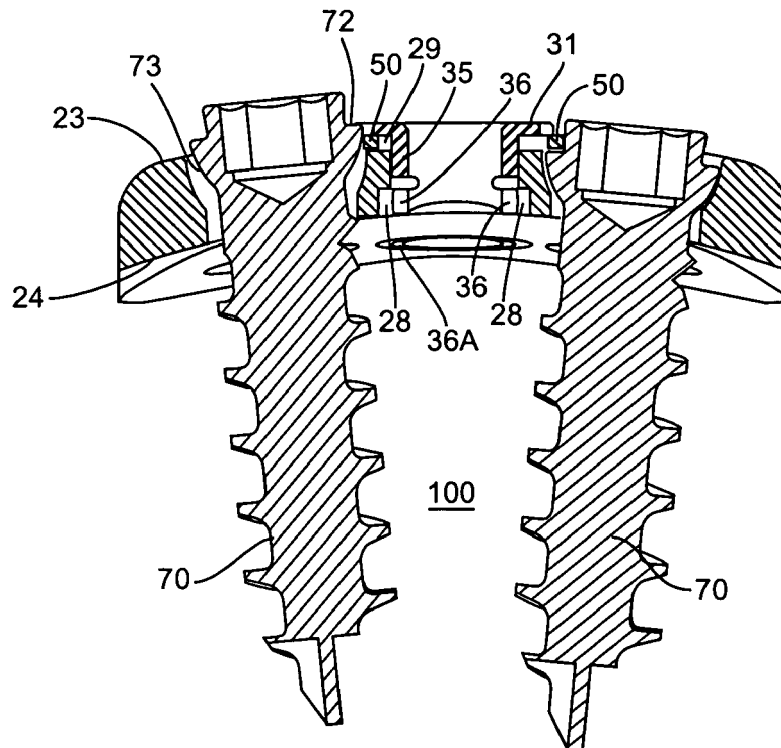
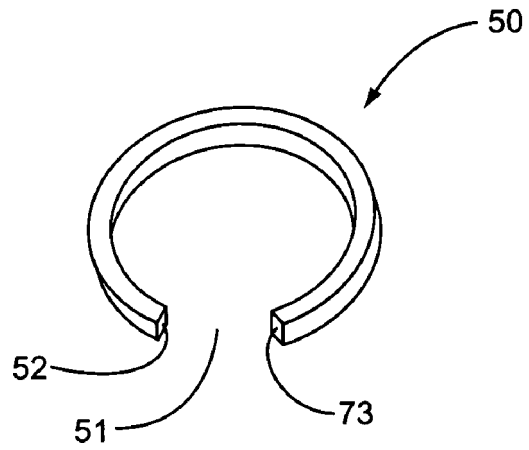
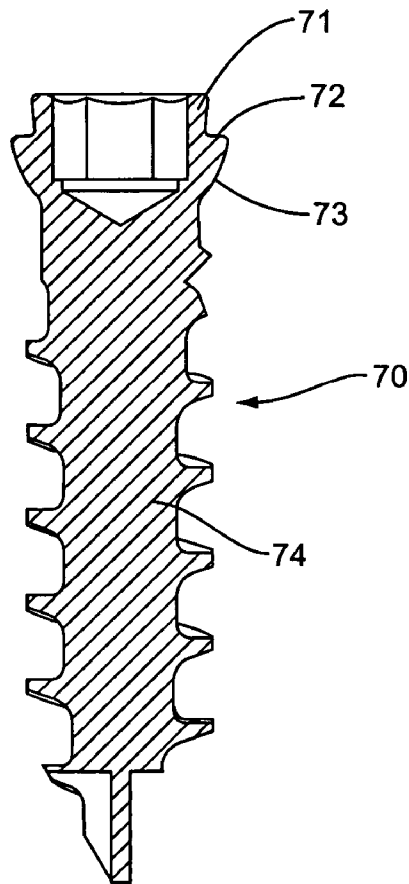

FIG. 5



**FIG. 6**



**FIG. 7**

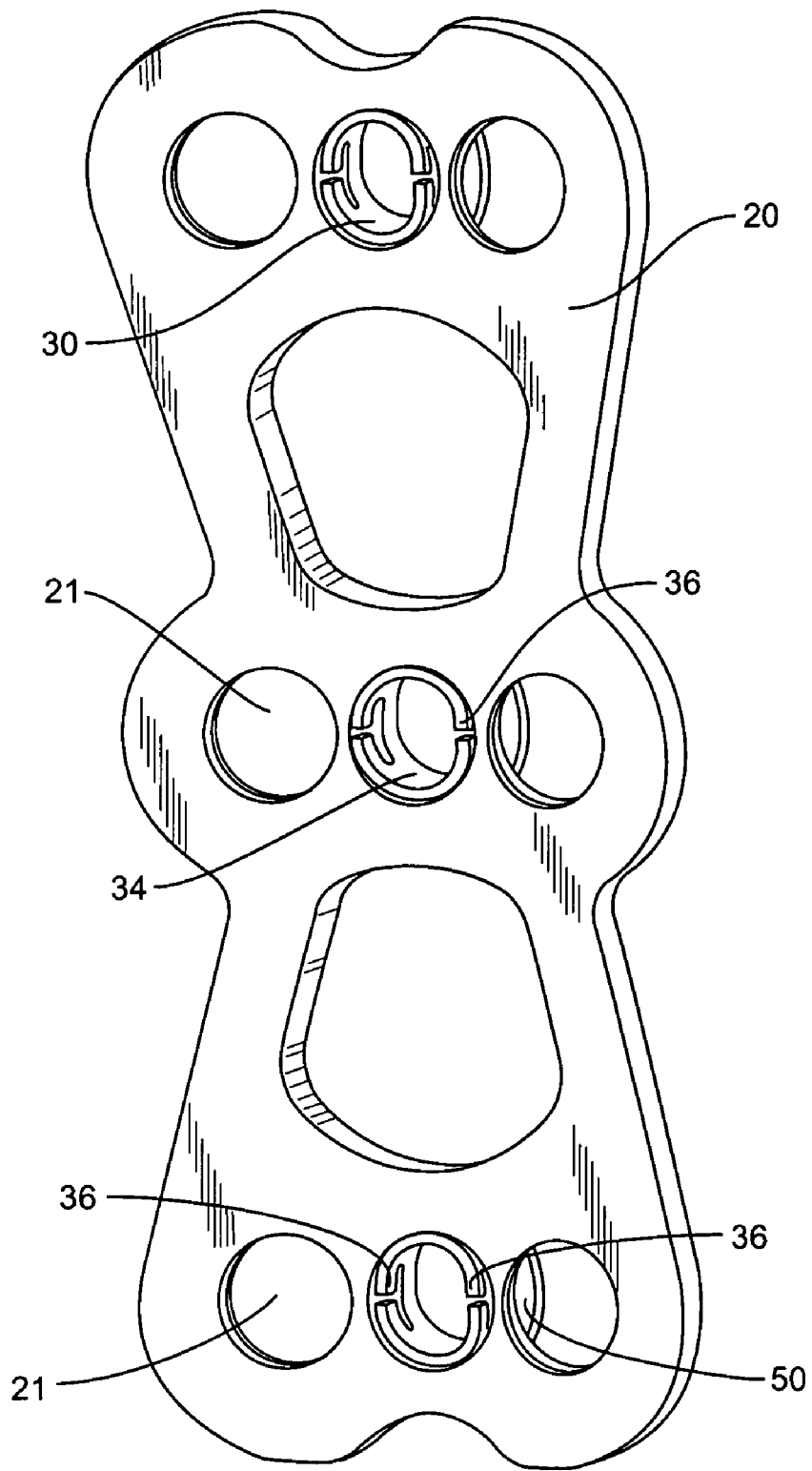

FIG. 8

## METHOD AND APPARATUS FOR RETAINING SCREWS IN A PLATE

### BACKGROUND

The human spine is a biomechanical structure consisting of thirty-three vertebral members and is responsible for protecting the spinal cord, nerve roots and internal organs of the thorax and abdomen. The spine also provides structural support for the body while permitting flexibility of motion. In certain surgical procedures it is necessary to secure together two or more of the vertebral members. The procedure may be necessary for example as a result of physical trauma or degenerative diseases.

One type of surgical procedure includes attachment of a vertebral plate to the vertebral members. The vertebral plate is sized to extend across two or more of the vertebral members. One or more bone screws extend through apertures in the plate and into the vertebral members to secure the plate. One issue with the attachment is the screws may tend to loosen and back-out of the vertebral members. Screw retention devices may be necessary to prevent the screw from backing-out of the vertebral members.

One type of screw retention device utilizes a snap ring that expands as the screw is inserted into the aperture and then retracts to a smaller diameter once the screw head has passed the level of the snap ring. One issue with previous snap ring designs is the inability to use the rings with a variety of different screws. These designs may not be effective for both variable angle and fixed angle screws, or require specialty screws that are design for only a limited application. Additionally, these previous designs have needed a larger plate thickness to accommodate the snap ring. Another issue is the difficulty for the surgeon to visually see when the lock ring has moved over the top of the screw once the screw has passed the level of the snap ring. Some designs also prevent or limit the ability of the surgeon to tactilely feel the movement of the snap ring as it moves over the top of the screw. Additionally, some designs interfere with the surgeon's feel of the screw purchasing within the bone.

### SUMMARY

The present invention is directed to a system and method of retaining screws within a vertebral plate and prevent screw back-out. The invention includes a variety of embodiments, with one embodiment having a plate with at least one aperture for receiving a screw. A cavity is positioned within the plate and partially overlaps into the aperture. A ring is positioned within the cavity and held in position by a cap. The ring is resilient and changes shape between an original shape that extends partially over the aperture, and a deflected shape away from the aperture.

Methods of retaining the screw are also disclosed. One method includes positioning a resilient member within a cavity in the plate such that it partially extends over the aperture. The next step comprises placing a cap over the cavity and attaching the cap to the plate to prevent the resilient member from being removed from the plate. The next step includes inserting a screw into the aperture and deflecting the resilient member away from the aperture. The screw is inserted into the vertebral member a predetermined distance, and the resilient member is returned to its original shape over the aperture and over the screw to prevent the screw from backing-out of the aperture.

## BRIEF DESCRIPTION OF THE DRAWINGS

FIG. 1 is a partially-exploded front view of the plate with a ring and cap according to one embodiment of the present invention;

FIG. 2 is a front perspective view of the cap according to one embodiment of the present invention;

FIG. 3 is a back perspective view of the cap according to one embodiment of the present invention;

FIG. 4 is a cross-sectional view illustrating the ring extending over a pair of screws according to one embodiment of the present invention;

FIG. 5 is a cross-sectional view illustrating the ring extending over a first aperture and being biased inward away from a second aperture according to one embodiment of the present invention;

FIG. 6 is a perspective view of the ring according to one embodiment of the present invention;

FIG. 7 is a cross-section view of a screw mounted within the plate according to one embodiment of the present invention; and

FIG. 8 is a rear perspective view of the plate with caps mounted within the cavities adjacent to the screw-receiving apertures according to one embodiment of the present invention.

### DETAILED DESCRIPTION

The present invention is directed to a retention system for maintaining the position of a screw 70 relative to a vertebral plate 20. FIG. 1 illustrates one embodiment of a vertebral plate 20 having one or more apertures 21. A cavity 22 is positioned adjacent to and overlaps into the aperture 21. A ring 50 is positioned within the cavity 22 and held in position by a cap 30. The cap 30 attaches to the plate 20 to prevent removal of the ring 50. The ring 50 is resilient and changes shape between an original shape that extends over an aperture 21 to prevent screw back-out, and a deflected shape that allows insertion and removal of the screw from the aperture 21 (see FIGS. 4 and 5).

The plate 20 is sized to extend across one or more vertebral members 100. Apertures 21 extend through the plate 20 between a top surface 23 and a bottom surface 24 to receive the bone screws 70. The apertures 21 may have a variety of sizes and orientations depending upon the specific application. The cavity 22 is positioned adjacent to the aperture 21 and includes a counterbore 29 that extends inward into the plate 20 from the top surface 23. The cavity 22 may extend entirely through the plate 20, or may extend only a limited distance into the plate 20 from the top surface 23. A depth that the counterbore 29 extends into the top surface 23 may likewise vary depending upon the application. The counterbore 29 may form an upper ledge 25 to accommodate the ring 50 as will be explained later. In one embodiment, the cavity 22 and counterbore 29 are co-axially aligned and each has a substantially circular shape. Various other shapes may also be employed and are contemplated by the present invention. In one embodiment, the cavity 22 and counterbore 29 are both centered within the medial plane M of the plate 20. The plate 20 may have both a medial and lordotic curve to conform to the dimensions of the vertebral members 100. The cavity 22 may further include elements to assist with retaining the cap 30. For example, a second counterbore 28 may be formed in the bottom surface 24 of the plate 20.

FIGS. 2 and 3 illustrate front and rear perspective views of the cap 30 removed from the plate 20. The cap 30 includes a flange 31 and an outwardly extending plug 34. The flange 31



includes an upper surface 32 and a lower surface 33. When mounted in the plate 20, the flange 31 seats within the counterbore 29 with the upper surface 32 substantially flush with the top surface 23 of the plate 20. The plug 34 has a width generally corresponding to the size of the cavity 22. Ears 36 and slots 39 may be positioned at the edge of the plug 34 opposite the flange 31 and mate with the lower counterbore 28.

A window 37 may be formed in the plug 34 and provide a contact point for grasping and manipulating the cap 30 and/or plate 20 during a surgical procedure. The window 37 may also be used for location and orientation of surgical instruments, such as plate holders, drills, taps, and screw guides. The window 37 may extend through the entire cap 30, or may extend only a limited distance inward from the upper surface 32 of the flange 31. The window 37 may have a shape to allow medial alignment of the plate 20, such as the oval shape illustrated in the Figures.

The cap 30 is attached to the plate 20 and maintains the ring 50 within the cavity 22. A variety of means may be used for attaching the cap 30 to the plate 20, including for example, interference fit, snap fit, staking, and swaging. In one embodiment, the cap 30 has external threads along the plug 34 that mate with threads on the inner wall of the cavity 22. The cap 30 may also be attached via a removable or non-removable fastener, such as screw, rivet, and the like. FIGS. 4 and 5 illustrate one method of attaching the cap 30 to the plate 20. The external features of the plug 34 are sized to contact the sidewall of the cavity 22 and provide an interference fit. Additionally, the ears 36 extend outward into the lower counterbore 28 to further secure the cap 30. The ears 36 may be deformed into the lower counterbore 28 during the manufacturing process or alternatively by the surgeon or other medical personnel prior to or during the surgery. In one embodiment, the ears 36 are grasped by a tool and bent outward away from the cavity thus enlarging the width and preventing the cap 30 from being removed from the plate 20. In another embodiment, the cap 30 is constructed of a resilient material. When inserted into the cavity 22, the ears 36 resiliently rebound outward into the counterbore 28. The position of the ears 36 within the counterbore 28 are illustrated in FIGS. 4 and 5. Ears 36A illustrate the mounting of the adjacent upper cap 30 (i.e., the cap 30 positioned adjacent to the cross-sectionally cut middle cap 30). In these embodiments, the cap 30 may be retained by only the interference fit, only the deformed ears 36, or by both.

The ring 50 is positioned within the cavity 22 to prevent back-out of the screw 70. The ring 50 is constructed of a resilient spring material that is elastic and deflectable between an original shape when mounted in the cavity 22 that extends outward into the aperture 21, and a deflected state away from the aperture 21 to allow removal and insertion of the screw 70 relative to the aperture 21. FIG. 6 illustrates one embodiment of the ring 50 having a substantially circular shape with inner and outer diameters and a compression slot 51 formed between first and second ends 52, 53. Ring 50 has upper and lower surfaces with the lower surface positioned towards the upper ledge 25 of the counterbore 29. In one embodiment, the lower surface is substantially flat to contact the screw 70 when the ring 50 extends into the aperture 21. FIG. 6 illustrates one embodiment of ring 50 having a rectangular cross-sectional shape. Another embodiment features a triangular cross-sectional shape.

The ring 50 may be constructed of a material having elastic properties. In one embodiment, the ring 50 is made of a Nickel-Titanium alloy that is heat treated to achieve super-elastic properties when exposed to a temperature range within

the human body. The ring 50 may also be constructed of other materials, for example, peek, titanium, or stainless steel. The term "ring" is used broadly herein to refer to the member positioned within the cavity. It is understood that the member may have a variety of different shapes and sizes.

In one embodiment, the diameter of the counterbore 29 is less than an outer diameter of the ring 50. This causes the ring 50 to be pre-loaded in the original shape when seated in the counterbore 29. The pre-loaded condition causes the compression slot 51 to be reduced and gives the ring 50 additional expansion force to extend outward over the aperture 21. The amount of deflection of the ring 30 may vary depending upon the application. Deflection may occur on one side of the ring 30, or on both sides such as would occur in an embodiment as illustrated in FIGS. 1, 4, and 5 as both screws 70 were being inserted.

FIG. 7 illustrates one embodiment of the screw 70 and includes a head 71, shelf 72, spherical radius 73 and shaft 74. The shelf 72 extends outward beyond the head 71 and provides a platform for receiving the ring 50. The shelf 72 may be substantially flat to provide a good contacting surface for the flat surface of the ring 50. The spherical radius 73 has a maximum width at the shelf 72 and reduces to a minimum width at the shaft 74.

FIGS. 1, 4, and 5 illustrate one embodiment of the invention having a cavity 22 positioned between and overlapping into two apertures 21. Each of the apertures 21 and cavities 22 has a substantially circular shape with the cavity 22 having a counterbore 29 that overlaps into the apertures. The ring 50 has an original shape that extends outward and overlaps into the apertures 21, and a deflected shape in a non-overlapping position away from the aperture 21. In one embodiment, the ring 50 is in the original shape prior to screw insertion, and after the screw 70 has been inserted into the aperture 21 and the shelf 72 passes below the level of the ring 50. FIG. 4 illustrates the ring 50 in the original shape where the shelf 72 is below the level of the ring 50. The resilient nature of the ring 50 causes it to return toward the original shape and extend over the shelf 72. The ring 50 position prior to screw insertion is illustrated within the middle cavity 22 and apertures 21 of the plate 20 in FIG. 1.

The insertion and removal of the screw 70 from the aperture 21 causes the ring 50 to deflect and move away from the aperture 21. One example is illustrated within the left screw 70 illustrated in FIG. 5. The force of the insertion or removal deflects the ring 50 inward from the aperture 21 and further into the counterbore 29.

The ring 50 overlaps into the apertures 21 a distance once the screw 70 has been inserted to prevent back-out of the screw 70. In one embodiment, the ring 50 extends outward beyond the edge of the cap flange 31 to allow visual confirmation of the position by a surgeon. This may further be assisted by coloring the ring 50 and screw 70 with contrasting colors to make it easier to visually observe the relative position of these elements.

The cap flange 31 may have a shape that conforms to the adjacent aperture 21 and prevents the flange 31 from extending over the aperture 21 when the cap 30 is mounted to the plate 20. As illustrated in FIGS. 2 and 3, the flange 31 has curved edges 38 that conform to the outer circumference of the aperture 21. Therefore, the flange 31 does not overlap into the aperture 21 while still allowing the ring 50 to overlap into the aperture 21.

The ring 50 is positioned in the space created between the cap 30 and cavity 21. In one embodiment, both the cap 30 and ring 50 are co-axially aligned within the cavity 22. As illustrated in FIGS. 2 and 3, a tab 35 extends outward from the cap

5

30 to fit within the ring slot 51 and prevent rotation of the ring 50. The tab 35 includes first and second edges that are distanced apart to fit within the slot 51 of the ring 50. This prevents rotation of the ring 50 to a position where the slot 51 is over the aperture 21 and potentially allows the screw 70 to back-out. Tab 35 seats against the upper ledge 25 of the counterbore 29 when the cap 30 is in the cavity 22.

As the screw 70 is inserted into the aperture 21, the spherical radius 73 contacts the ring 50 and deflects it away from the aperture 21. As the insertion of the screw 70 continues, the ring 50 is further deflected from its original shape and away from the aperture 21. After insertion has progressed beyond the point where the spherical radius 73 is below ring 50, the ring 50 returns towards the original shape to extend over the shelf 72. The snapping action of the ring 50 extending over the shelf 72 may be tactilely detected by the surgeon and provide assurance that the ring 50 is seated over the screw 70 to prevent back-out. The elastic property of the ring 50 causes a snapping action as the screw passes and does not require the surgeon to proactively engage the ring 50.

Another embodiment of the device includes the ring 50 attached to the cap 30. The ring 50 and cap 30 combination may be a single integral piece, or the ring 50 may be a separate piece that is fixedly attached to the cap 30. In these embodiments, the combination positions the ring 50 over the apertures 21 in the original shape and allows the ring 50 to be deflected upon screw 70 insertion and removal.

The original shape of the ring 50 is positioned to extend over one or more apertures 21. This original shape may not be the neutral position of the ring 50. By way of example, the shape of the ring 50 may be constrained by the counterbore 29 and have a smaller outer width than if the ring 50 were more freely positioned within a larger space. Additionally, the ring 50 may be in a more deflected state when it returns over the aperture 21 after insertion of the screw 70. In one instance, screw 70 is in the original shape and extends over the aperture 21 a first amount. During screw 70 insertion, ring 50 deflects away from the aperture 21 to a second shape. After screw 70 insertion, ring 50 snaps back over the screw 70 to a third shape. This third shape may be the same as the original shape, or may be different depending on the position and size of the screw. By way of example, the ring 50 may contact the screw head 71 in the third shape and prevent the ring 50 from fully returning to its original shape.

The ring 50 may further deflect along a single side, or along more than one side. In the embodiment illustrated in FIGS. 1, 4, and 5, ring 50 extends into two apertures 21 and therefore can be deflected along two separate sides as screws 70 are inserted into the respective apertures 21. In another embodiment where the ring 50 extends only into a single aperture 21, the ring 50 will deflect along a single side.

The term vertebral member is used generally to describe the vertebral geometry comprising the vertebral body, pedicles, lamina, and processes. The device may be sized and shaped, and have adequate strength requirements to be used within the different regions of the vertebra including the cervical, thoracic, and lumbar regions.

FIG. 1 is included in part to illustrate the relative positioning of the plate 20, ring 50, and cap 30. Neither a cap 30 or ring 50 are attached to the upper cavity 22 to illustrate the position of the cavity 22 and counterbore 29 relative to the adjacent apertures 21. A cap 30 and ring 50 are mounted in the middle cavity to illustrate the ring 50 extending outward into the adjacent apertures 21 when there are no screws 70. The lower cavity 22 illustrates the cap 30 and ring 50 in an exploded view.

6

The present invention may be carried out in other specific ways than those herein set forth without departing from the scope and essential characteristics of the invention. The ring 50 may also have a circular, oval, or elongated cross-sectional shape. In one embodiment, the ears 36 are positioned within the lower counterbore 28 and are either flush or recessed within the bottom surface 24 of the plate so as not to interfere with positioning on the vertebral member 100. In one embodiment, the ring 50 extends over the screw head 71 to prevent screw back-out. In this embodiment, the screw 70 may or may not include a shelf 72 and spherical radius 73. In one embodiment, the plug 34 and flange 31 form an angle of about 90°. The retaining system has been discussed in the context of a vertebral plate, however, the system is also applicable to other applications in the body using plates and attachment screws. In one embodiment where the cavity 22 is positioned between two apertures 21, a center of the cavity 22 is positioned along a line formed between the centers of the two apertures 21. The present embodiments are, therefore, to be considered in all respects as illustrative and not restrictive, and all changes coming within the meaning and equivalency range of the appended claims are intended to be embraced therein.

What is claimed is:

1. A screw retaining system comprising:

- a plate having an aperture to receive a screw, the aperture extending between a top surface and a bottom surface; a cavity extending into the plate from the top surface, the cavity positioned to overlap into the aperture;
- an elastic member positioned within the cavity and changeable between a first shape to prevent the screw from backing-out of the aperture and a second shape to allow the screw to back-out of the aperture; and
- a cap attached within the cavity to prevent the elastic member from being removed from the plate;
- the elastic member extending outward from the cap and into the aperture in the first shape, the cap positioned to be in a non-overlapping arrangement with the aperture when the elastic member is in the first shape;
- wherein the elastic member is substantially C-shaped having a curved body with a slot formed between first and second ends.

2. The system of claim 1, wherein the cavity is located at the medial section of the plate.

3. The system of claim 1, wherein the cavity comprises an upper ledge sized to position the elastic member and a lower section between the upper ledge and bottom surface of the plate, the upper ledge having a width greater than the lower section.

4. The system of claim 3, wherein the cap comprises a flange positioned on the upper ledge and a plug that attaches within the lower section to mount the cap to the plate.

5. The system of claim 1, wherein an upper surface of the cap is substantially flush with the top surface of the plate when the elastic member is mounted to the plate.

6. The system of claim 1, wherein the elastic member has a substantially flat bottom surface.

7. The system of claim 1, wherein a tab on the cap is positioned within the slot in the elastic member to prevent the elastic member from rotating within the cavity beyond a predetermined amount.

8. The system of claim 1, wherein the cap includes an elongated opening.

9. The system of claim 1, wherein an edge of the cap has a curved surface that aligns with the aperture such that the cap is positioned away from and does not overlap into the aperture.

10. The system of claim 1, wherein the elastic member is deflected in the second shape.

11. The system of claim 1, wherein the cavity is narrower than the elastic member in a neutral state causing the elastic member to be in a pre-load condition in the first shape.

12. The system of claim 1, wherein the plate has an elongated shape to extend over a plurality of vertebral members.

13. The system of claim 1, wherein the cavity extends completely through the plate.

14. The system of claim 13, further comprising a counterbore positioned on the bottom surface of the plate to receive ears on a lower section of the cap.

15. A screw retaining system plate comprising:

a plate having an aperture sized to receive the screw;

a cavity extending into the plate with a counterbore that overlaps into the aperture;

an elastic member positioned within the counterbore and elastically deflectable to control screw access to the aperture; and

a cap having a flange and a plug, the flange positioned at least partially over the cavity and the plug positioned through an interior section of the elastic member and mating with the plate to attach the cap to the plate, the cap positioned to be in a non-overlapping arrangement with the aperture when the elastic member is positioned within the counterbore to control screw access to the aperture;

wherein the flange has a curved edge that aligns with the aperture such that the flange does not extend into the aperture.

16. The system of claim 15, wherein the plug includes ears that are deformable to mount with sidewalls of the cavity.

17. The system of claim 15, wherein the cavity is located at the medial section of the plate.

18. The system of claim 15, wherein the cap has a substantial T-shape with the plug extending outward from the flange at an angle of about 90°.

19. The system of claim 15, wherein the cap includes an elongated window through the flange and extending at least partially through the plug.

20. A vertebral plate system comprising:

a plate having an aperture, the aperture extending between a top surface and a bottom surface;

a countebore extending into the plate from the top surface and having a depth less than the aperture, the counterbore positioned to overlap into the aperture;

an elastic member having a bottom surface and being positioned within the counterbore and deflectable between first and second shapes;

a cap attached to the plate to maintain the elastic member within the counterbore, the cap positioned to be in a non-overlapping arrangement with the aperture when the elastic member is in the first shape that extends into the aperture; and

a screw having a shelf extending outward from a central axis of the screw, the shelf being substantially flat to contact the bottom surface of the elastic member when the elastic member is in the first shape.

21. The system of claim 20, further comprising a spherical radius adjacent to the shelf and having a maximum width at the shelf and a minimum width a distance from the shelf closer to an insertion end.

22. The system of claim 20, wherein the elastic member has a substantial C-shape with a curved body and first and second ends that are spaced apart forming a slot.

23. The system of claim 20, wherein the elastic member has a substantially rectangular cross-sectional shape.

24. A screw retention system comprising:

a plate having a top surface and a bottom surface;

a cavity positioned within the plate and extending between the top surface and the bottom surface;

an aperture positioned within the plate and extending between the top surface and the bottom surface;

a first counterbore aligned with the cavity and extending into the plate from the top surface and overlapping into the aperture, the first counterbore being wider than the cavity;

a second counterbore aligned with the cavity and extending into the plate from the bottom surface, the second counterbore being wider than the cavity;

an elastic member within the first counterbore and having a first shape that extends into the aperture and a second shape away from the aperture; and

a cap extending over at least a section of the elastic member and having at least one ear positioned in the second counterbore to attach the cap to the plate.

25. The system of claim 24, wherein the first and second counterbores are each axially-aligned with the cavity.

\* \* \* \* \*